

## CONSERVATOR PROTECTION RELAY (CPR)

**MODELS : CPR-ME-3, CPR-MT-3**

### 1.0 APPLICATION :

The Conservator Protection Relay (CPR) is a safety device suitable for the conservator of the oil filled transformer in which an Aircell (Flexi Separator) is provided. CPR is designed to protect the transformer when the Aircell ruptures or opens and the air inside the Aircell is released in the conservator.

### 2.0 MODELS:

- 2.1 Model CPR-ME-3 ( With SPST Reed Switch )
- 2.2 Model CPR-MT-3 ( With Changeover reed Switch )

### 3.0 CONSTRUCTION & WORKING :

A die cast aluminium housing is used. The housing is provided with a mounting flange at the bottom. The integral flange has 4 holes of 11.5 dia at 75 PCD for mounting. The housing has a die cast cover which seals the housing with the help of an 'O' Ring. The inner side of cover has a switching mechanism. The switch operates when air released from the Aircell enters the housing. A window is provided in the housing with graduated scale to read the volume of air. As a standard practice, the CPR is set to operate at  $400 \pm 50$  CC.

On top side, a Terminal Box with cover is provided. To make the Terminal Box weather proof, a gasket is provided for the cover of Terminal Box. The leads from the Switch are brought in the Terminal Box. Two or three terminals are provided depending on selection of Model.

Two Cable Entries with M 25 x 1.5 threads are provided in the Terminal Box for fitting Cable Gland for incoming cable. Thus the wiring can be done by opening the cover of the Terminal Box & by using suitable Cable Gland. An arrangement is provided on the Cover for manually testing the switch operation. Thus operation of the switch can be checked manually at any time. The switch testing mechanism is provided with a removable cap. By removing the cap, the switch testing mechanism is accessible.

A petcock with 1 /4" BSP threads is provided on top side of cover of Housing for venting out the air in the conservator during installation of CPR. The opening of petcock is provided with a removable brass cap.

Two openings for Cable Gland are provided. One hole is closed with brass plug & the other with plastic plug. The Port Opening of 40 dia in the housing is closed by a plastic plug. These plastic plugs are to be removed before installation & wiring of CPR.

### 4.0 MOUNTING:

To install the CPR, a Mounting Pad as shown in Fig. 2 has to be provided on top of conservator. The orientation of Mounting Pad should be done in such a way that the window of CPR is easily visible after installation. 4 Nos, M 10 bolts, nuts, washers & the gasket should be provided.

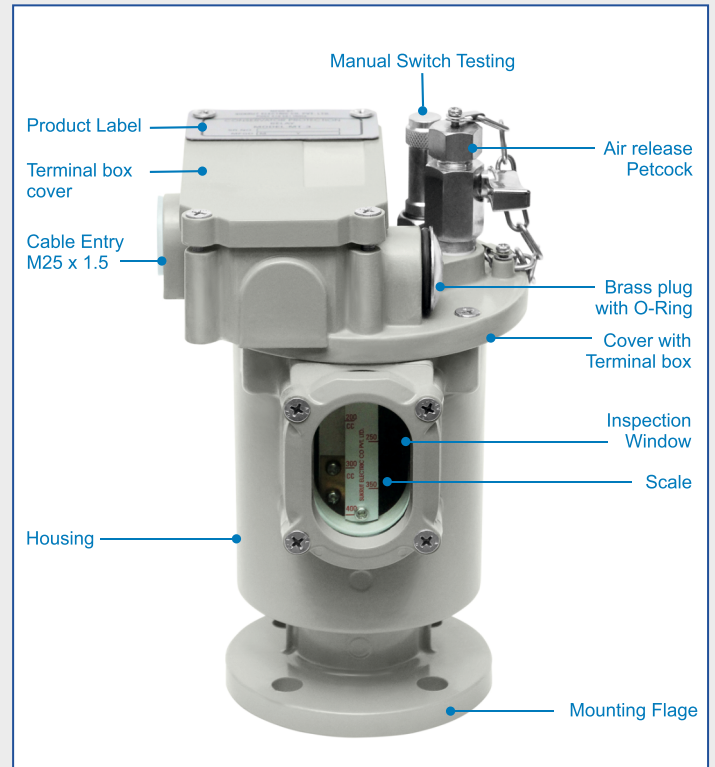

### 5.0 FEATURES :

- 5.1 Lightweight due to use of die cast aluminium casting.
- 5.2 Can work in seismic prone zone due to use of magnetic reed switch.
- 5.3 Gives electrical signal when Aircell (Flexi Separator) ruptures or opens after commissioning.

### 6.0 SPECIFICATIONS:

- |     |                       |   |
|-----|-----------------------|---|
| 6.1 | Liquid in Conservator | : Transformer Oil - IS-335                        |
| 6.2 | Working Temperature   | : $-10^{\circ}$ to $115^{\circ}$ C                |
| 6.3 | Working Pressure      | : 0 to 1 kg/cm <sup>2</sup>                       |
| 6.4 | Environment           | : Indoor or Outdoor                               |
| 6.5 | Operation of Switch   | : When air volume in CPR reaches $400 \pm 50$ CC. |
| 6.6 | Ingress Protection    | : IP-67   |
| 6.7 | Corrosion Resistance  | : C4-M  |

### 7.0 ROUTINE TESTS :

- 7.1 Switch operation test at air volume  $400 \pm 50$  CC.
- 7.2 Leakage test for CPR at 2.5 Kg/cm<sup>2</sup>
- 7.3 HV test at 2 kV for one minute between live terminals & body.

### 8.0 HOW TO ORDER :

Select the Model & send enquiry to SECPL.



# CONSERVATOR PROTECTION RELAY

## MODELS : ME-3 & MT-3

FIG 1.

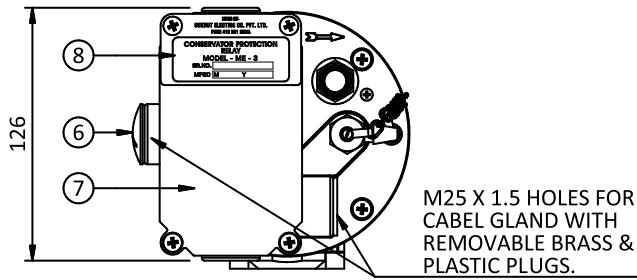

TOP VIEW

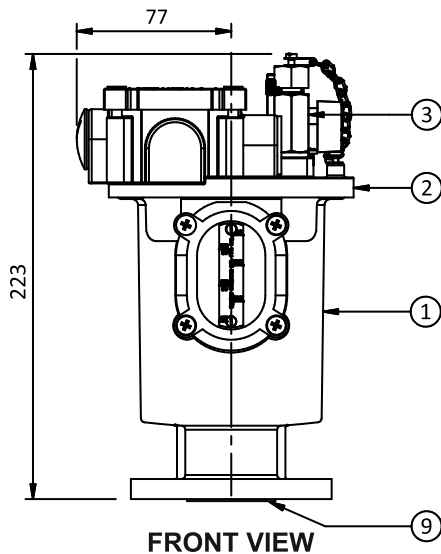

FRONT VIEW

PART LIST FOR FIG 1.

SR NO.	DESCRIPTION	MATERIAL	QTY
1.	HOUSING	ALUMINIUM	1
2.	COVER	ALUMINIUM	1
3.	PETCOCK 1/4" BSP WITH CAP	BRASS	1
4.	ELECTRIC TESTING DEVICE WITH CAP	BRASS	1
5.	PLAIN PLUG	PLASTIC	1
6.	PLUG M25 x 1.5	BRASS	1
7.	TERMINAL BOX WITH COVER	ALUMINIUM	1
8.	PRODUCT LABEL	ALUMINIUM	1
9.	PLUG D40	PLASTIC	1

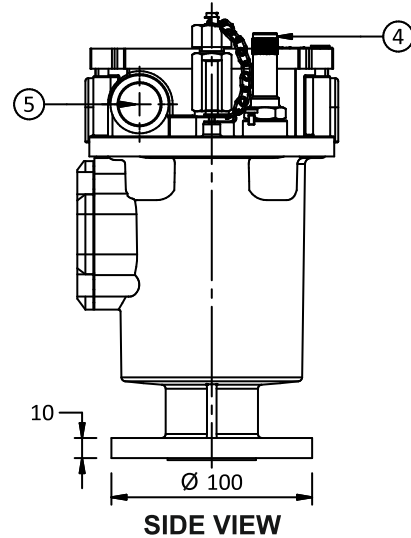

SIDE VIEW

**Notes:**

1. All dimensions are in 'MM'
2. Except mounting dimensions, all other dimensions are for reference only.
3. Mounting pad & gaskets are not supplied by SECPL.

FIG 2. MOUNTING PAD

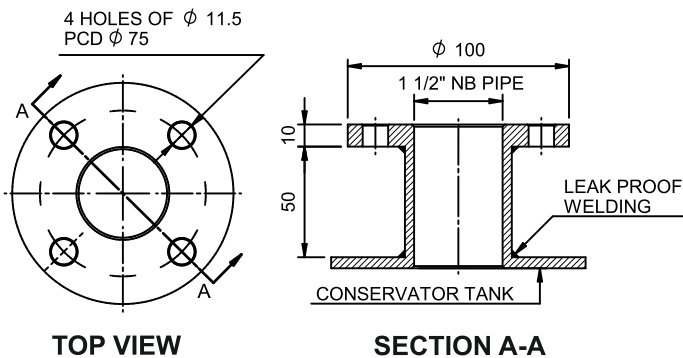

TOP VIEW

SECTION A-A

FIG 3. WIRING DIAGRAM

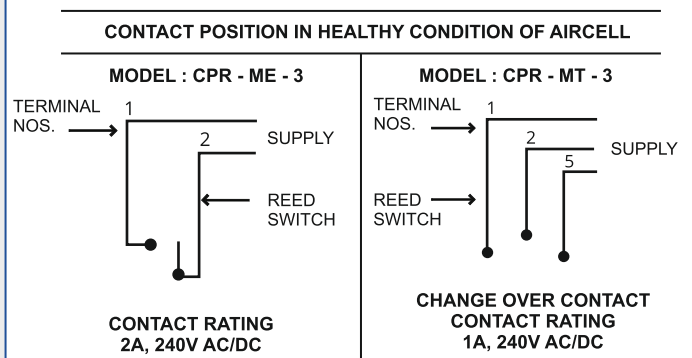

**GENERAL NOTES :**

1. This Model of CPR is suitable for any size of Conservator. It must be mounted at the top of Conservator.
2. The CPR is delicate instrument. It should be stored properly.
3. Complaint of damage or demand for spares should be very specific with respect to Serial Number of CPR. Lot of correspondence & time can be saved just by informing Serial Number of CPR.



**SUKRUT ELECTRIC CO. PVT. LTD.**

Plot No. Pap-B-63, MIDC Chakan Industrial Area Phase - II, Village Bhamboli, Taluka Khed District Pune 410 501, Maharashtra, India.

Mobile : +91 75077 78841 / 75077 78842

Email : marketing@sukrutelectric.com

Web : www.sukrutelectric.com

